

NS SERIES

28-847S

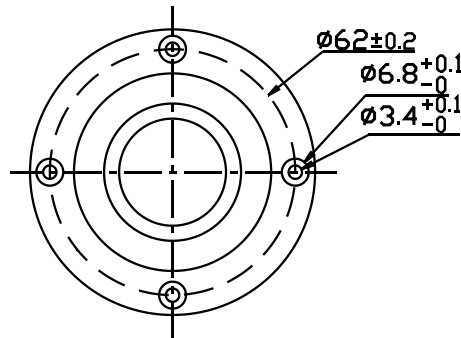
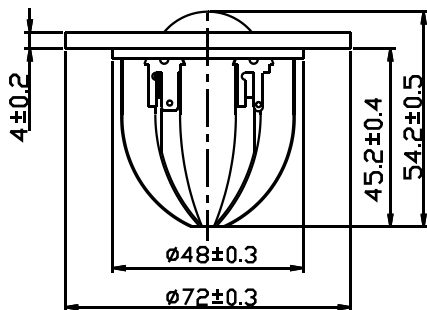

- SOFT FABRIC DOME DIAPHRAGM COATING WITH HIGH LOSS MATERIAL
- FERROFLUID COOLED
- DAMP WOOL IN CAVITY OF POLE PIECE
- NYLON (15% GF) FRONT PANEL & BACK CHAMBER
- MAGNETICALLY SHIELDED
- BACK CHAMBER DESIGN

28mm FABRIC DOME

DIAPHRAGM MTL	Fabric
SURROUND MTL	N/A
NOMINAL IMPEDANCE	8
DCR IMPEDANCE	6
SENSITIVITY 1W/1m	90 dB
FREQUENCY RESPONSE	600-20K Hz
FREE AIR RESONANCE	600 Hz
VOICE COIL DIAMETER	28 mm
AIR GAP HEIGHT	2 mm
RATED POWER INPUT	15 W
MAXIMUM POWER INPUT	120 W
FORCE FACTOR, BL	N/A
MAGNET WEIGHT (oz)	Neodymium
MOVING MASS	N/A
FERROFLUID ENHANCED	Yes
SUSPENSION COMPLIANCE	N/A
EFFECTIVE PISTON AREA	N/A
Levc	0.265 mH
Zo	11.0944 ohm
X-max	N/A
Vas	N/A
Qts	N/A
Qms	N/A
Qes	N/A

